

Data sheet

Extractor hood

Limatec
Küchen- und Haushaltstechnik

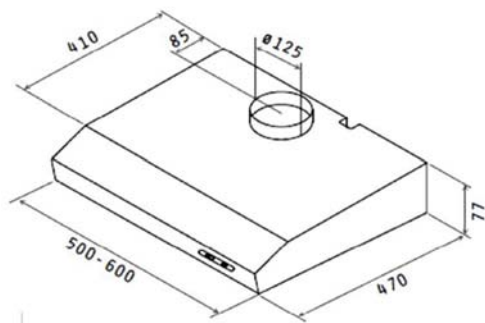

DH 520 white

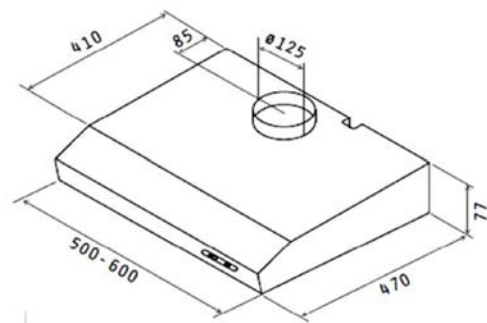

DH 540 silver

Technical specifications

| | |
|--|---------------|
| Annual energy consumption | 59,4 kW/h |
| Energy efficiency class | D |
| Fluid dynamic efficiency class: | G |
| Lighting efficiency class: | G |
| Grease filter efficiency: | C |
| Exhaust performance in accordance with EN 61591 (valid as of 01.01.2015) | 125 m³/h |
| max. noise level | 62 dBA |
| Operating voltage | 230 V - 50 Hz |
| Engine | 1 x 100 W |
| Max. exhaust performance measured at engine | 190 m³/h |
| Pipe connection | 125 mm |

Equipment

| | |
|--|---------------------------------------|
| Slide switch | |
| Speed levels | 3 |
| Max. lighting | 1 x 28 Watt Halogen /E14 |
| Grease filter mat MI 152 (1 pack = 3 pcs.) | 1 (Initial delivery already included) |

Dimensions

| | |
|------------------------|------------------|
| Device ground (HxWxD) | 76 x 50 x 47 mm |
| Cardboard mass (HxWxD) | 125 x 55 x 53 mm |
| weight net | 4.05 kg |
| weight brut | 4.65 kg |

Technical specifications

| | |
|--|---------------|
| Annual energy consumption | 59,4 kW/h |
| Energy efficiency class: | D |
| Fluid dynamic efficiency class: | G |
| Lighting efficiency class:: | G |
| Grease filter efficiency:: | C |
| Exhaust performance in accordance with EN 61591 (valid as of 01.01.2015) | 125 m³/h |
| max. noise level | 62 dBA |
| Operating voltage | 230 V - 50 Hz |
| Engine | 1 x 100 W |
| Max. exhaust performance measured at engine | 190 m³/h |
| Pipe connection | 125 mm |

Equipment

| | |
|--|---------------------------------------|
| Slide switch | |
| Speed levels | 3 |
| Max. lighting | 1 x 28 Watt Halogen /E14 |
| Grease filter mat MI 152 (1 pack = 3 pcs.) | 1 (Initial delivery already included) |

Dimensions

| | |
|------------------------|------------------|
| Device ground (HxWxD) | 76 x 50 x 47 mm |
| Cardboard mass (HxWxD) | 125 x 55 x 53 mm |
| weight net | 4.05 kg |
| weight brut | 4.65 kg |